



Automatic Isokinetic Sampler

G4

With **G4**, TCR Tecora introduces the 4th generation isokinetic sampler.

It is the result of a long tradition of isokinetic sampler, started in 80s with Isostack B6.

The solution offered with this new instrument can be summarized in **4 main characteristics**:

MAIN CHARACTERISTICS

- ⊗ Fast isokinetic control at any stack condition;
- ⊗ Volume measurement with dry gas meter;
- ⊗ Sampling flow measurement with mass flow meter;
- ⊗ In-stack temperature and velocity measurement;
- ⊗ Autotest and anomalies management;
- ⊗ USB interface to download data;
- ⊗ Wide Graphic Display;
- ⊗ High precision pressure calibrator, with thermal drift compensation device;
- ⊗ Wide library with specifications of the most common ducts;
- ⊗ Data logger function with saving data on USB key (supplied with the instrument);
- ⊗ Graphic interface highly intuitive and simple;
- ⊗ Internal memory capability up to 256 report;
- ⊗ Reduced maintenance;
- ⊗ Available with ISO 17025 accredited laboratory certificate.

NEW UTILITIES

- ✓ Auto check at starting;
- ✓ Leak test in line during sampling;
- ✓ Calculation for MSSl impactor;
- ✓ Ducts library;
- ✓ Log measurements and alarms;
- ✓ Automatic re-start in case of flue gas velocity alarm.



Easy to use



Reliability



Accuracy



Sampling Quality
(QA/QC)



G4 All-in-One version

EASY TO USE

G4 offers two different configuration to meet different type of use. It is available in a "all in one" and in a "split" version. The first is dedicated to whom wish to reduce the costs and have the maximum portability. The second to whom wish to carry on stack platform only the control panel and leave on plant floor the pump unit. Probes and filter heating now managed directly from the integrated electronics of the instrument. New functionalities of the software allow to manage the sampling in an easy and intuitive manner.

Reduction of cables and connections toward probes and other devices: a single umbilical cable includes the cables for the heated uses.

Portability and sturdiness empowered through a steel and aluminium frame and ABS panels.

Sampling flow even more flexible with 4 or 8 m³/h.





RELIABILITY

G4 uses quality components which grant reliability in time.

Last generation electronics, which assures high immunity from electro-magnetic noisy and designed to work even in severe ambient conditions.

Advanced autotest functions: allow to point out anomalies and malfunctioning before starting the sampling and eventually to proceed bypassing the anomaly.

Simplified and reduced maintenance: the new pneumatic circuit, the components' arrangement and the removable wide carter frame, make the maintenance operations fast and easy to perform.

"Block pump" function, in case of accidental liquid suction: it switch off automatically the pump, avoiding its damage.

Software upgrade via USB: the customer can update the instrument himself every time a new software version is released.



G4 ONE version

ACCURACY / SAMPLING QUALITY (QA/QC)

G4 allows to follow quality control procedures for the automatic isokinetic sampling.

Calibration traceability of each sensor and measured parameter.

G4 stores each calibration performed by the user and the manufacturer.

The report is downloadable via USB.

Calibration curve on 5 points for each sensor and acquired width.

Correction curve on 5 points programmable by customer for each sensor.

Allows to adjust deviations eventually found during recalibration.

Volume measurement redundancy now coming from a **mass and a volume meter**.

Autocalibration function: permits to verify the calibration of flow and volume measurement elements and eventually to adjust them to an external reference.

High precision pressure sensor with thermal drift compensation.

Thermocouple calibration curve following ITS 90 standard.



G4 Interface details

PARAMETERS SAVED ON INSTRUMENT'S REPORT

- > Instrument's serial number;
- > Sampling date / hour;
- > Duct's temperature;
- > Duct's absolute pressure;
- > Flue gas velocity;
- > Duct's flow;
- > Duct's parameter;
- > Sampling duration;
- > Atmospheric pressure;
- > Sampling line pressure;
- > Sampled volume;
- > Nozzle's flowrate;
- > Sampler's range;
- > Isokinetic deviation;
- > Heated box temperature;
- > Heated probe temperature;
- > Condensation bath temperature;
- > Condensation bath's gas outlet temperature;

STORED REPORT TYPE

- > Measurement report;
- > Punctual report;
- > Sampled point summary;
- > Measurement log;
- > Parameter's record with time;
- > Programmable integration;

REPORT FORMAT

Compatible with the following systems:

- > Windows XP e successivi;
- > Linux;
- > Mac OS;
- > Google Chrome OS.

Compatible with:

- > Microsoft Office;
- > Database generico;
- > SUN Open Office suite.

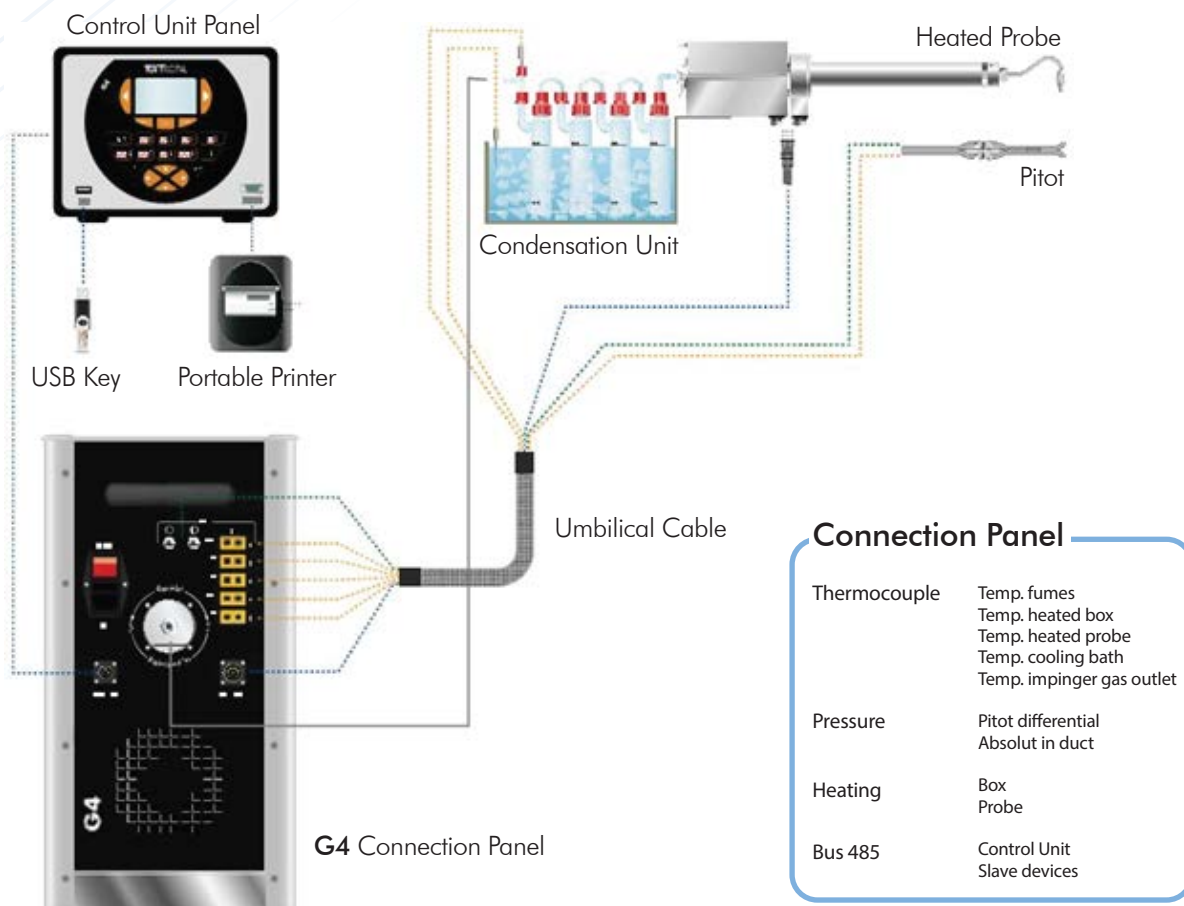

G4 is available with different configurations

G4 ONE	P. Supply (220 Vac ± 10% 50/60 Hz)	P. Supply (90 - 130 Vac ± 10% 50/60 Hz)
"All in one" Version 4 m ³ /h	AC99-025-0000SP	AC99-025-0010SP
"All in one" Version 8 m ³ /h	AC99-025-0001SP	AC99-025-0011SP

G4 TWO	P. Supply (220 Vac ± 10% 50/60 Hz)	P. Supply (90 - 130 Vac ± 10% 50/60 Hz)
"Split" Version 4 m ³ /h	AC99-025-0003SP	AC99-025-0013SP
"Split" Version 8 m ³ /h	AC99-025-0004SP	AC99-025-0014SP

Control Unit G4 TWO	AC99-025-0020SP
----------------------------	------------------------

Available Cables	
AC99-025-9920SP	Umbilical cable (Pitot + exhaust thermocouple) 5m, lengths available up to 40m.
AC99-025-9940SP	Integrated cable (Pitot + exhaust thermocouple + heaters for box and probe) 5m, up to 30m.
AC99-025-9960SP	Integrated EPA5 cable (Pitot + tk exhaust + heaters + 2 auxiliary thermocouples) 5m, up to 30m.

Optionals and Accessories



H ₂ O suction sensor	AC99-025-9901SP
Box probe thermoregulator	AC99-025-9902SP
n ^o 2 thermocouple inlet aux	AC99-025-9903SP
Automatic autozero	AC99-025-9904SP
Battery portable printer	AC99-025-9900SP
G4 One transport case	AC99-025-9906SP



TECHNICAL CHARACTERISTICS

Differential Pressure	
Range	0 - 2500 Pa (0-250 mmH2O) better
Accuracy	Than 1% of measure \pm 2 Pa 0.1 Pa
Resolution	(0.01 mmH2O)
Differential Pressure Max	30 000 Pa (3000 mmH2O)

Absolute pressure (static and barometric)	
Range	0 - 105 kPa (1050 mBar) absolute
Accuratezza	Better than 1% of measure \pm 2 Pa 0.1 Pa
Risoluzione	(0.01 mmH2O)

Temperature	
N° of Inlet for Thermocouple K Type	Up to 5 (depending on model)
Resolution	0.1 °C
Thermocouple Type K	0 + 1200 °C
Accuracy	1% of measure \pm 0.2 °C
Dry Gas Meter Temperature	Pt 100 sensor (4 spins)
Range	-20 + 80 °C
Accuracy	1% of measure \pm 0.2 °C
Resolution	0.01 °C

Volume Measurement	
With Dry Gas Meter	G2.5 o G4 (depending on model)
Resolution	0.1 litre
Accuracy	2%

Flow Measurement	
Answering Time	500 ms
Mass Meter	5 - 40 l/min (with 4 m ³ /h pump) 8 - 60 l/min (with 8 m ³ /h pump)
Resolution	0.01 lit
Accuracy	better than 2%

Range Regulation	
Type	Electronic
Answering Time	> 2%

General Specifications	
Suction Pumps	Rotative pumps 4 or 8 m ³ /h
Interception Duct's Valve	Totally isolated
Suction Gas Filter	Built-in Glass Fiber
Water Sensor	Built-in (*optional)
Gas Connections and Pitot	Quick connections
Communications Ports	USB 1.0; 1.1 e 2.0
Printer Port	RS232
Working Temperature	-20 + 40 °C 95% UR
Power Supply	220 Vac 50/60Hz - (100Vac 50/60Hz)
Working without Main Supply	Buffer Battery
Display	Graphic LCD 128x64 pixel
Keypad	Membrane with tactile effect
Weight	15 Kg (4 m ³ /h) 19 Kg (8 m ³ /h)

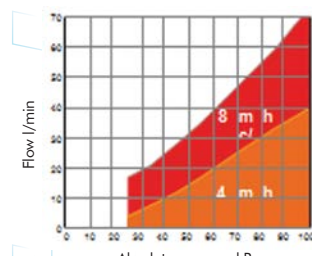

Compensation curve pump 4 e 8 m³/h

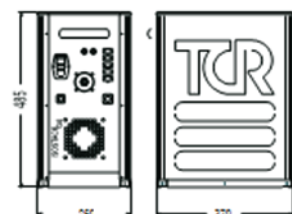

G4 Dimensions



G4 Control Unit Dimensions

4

